

VANEC

VERTICAL LUG SUPPORTS

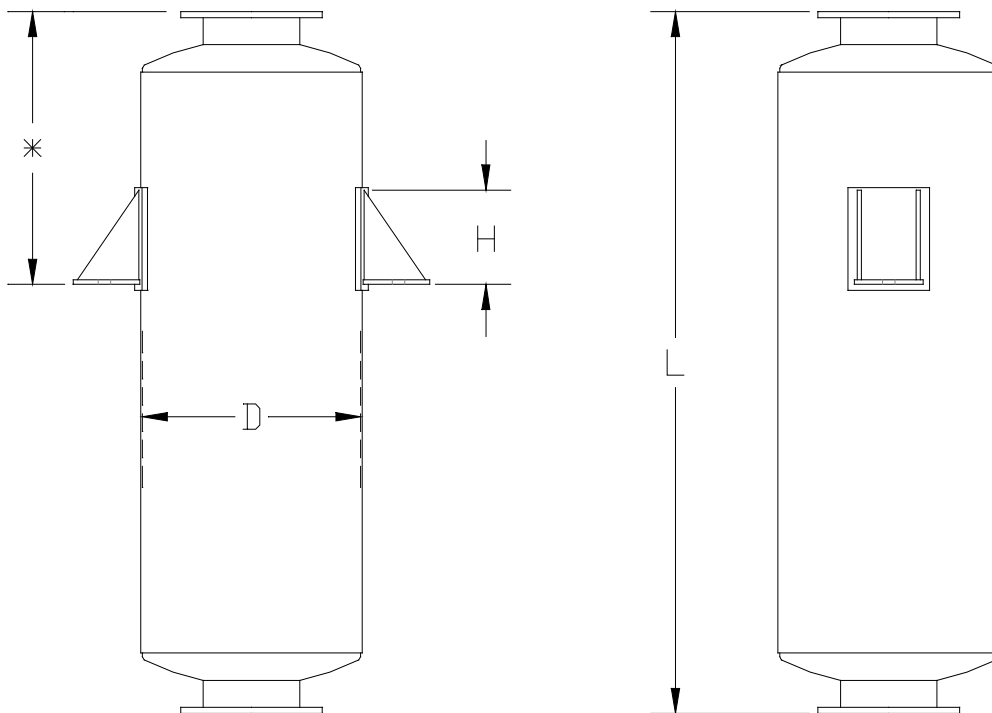
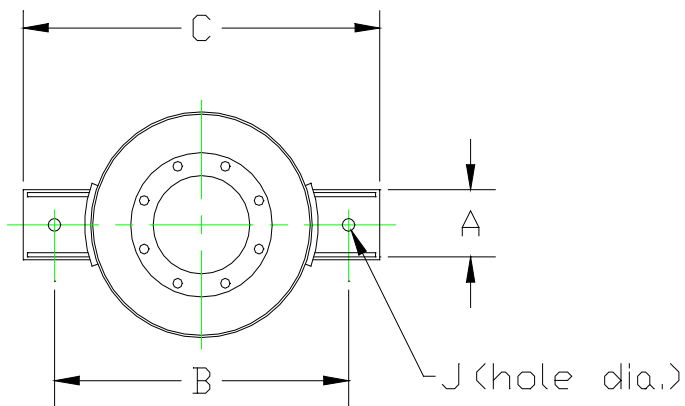

* Lugs typically set at $1/3 \times L$
(unless otherwise specified)

VERTICAL LUG SUPPORTS

D Silencer Nominal Dia.	Dimensions in Inches					Est. Wt. per Lug (Lbs.)
	A	B Bolt Circle	C	H	J Hole Dia.	
8	3	11	14	5	3/4	3
10	3	13	16	5	3/4	3
12	3	15	18	5	3/4	3
14	4	18	22	6	1	7
16	4	20	24	6	1	7
18	4	22	26	6	1	7
20	4	24	28	6	1	7
22	4	26	30	6	1	7
24	4	28	32	6	1	7
26	4	30	34	6	1	7
28	4	32	36	6	1	7
30	4	34	38	6	1	7
36	4	40	44	6	1	7
42	6	48	54	9	1½	12
48	6	54	60	9	1½	12
54	6	60	66	9	1½	12

Notes:

1. Dimensions may change depending on silencer weight and application load requirements.
2. Lugs available for larger diameter silencers upon request.

VANEC Industrial Silencers
716-827-4959