

VANEC

SKIRT & BASE RING

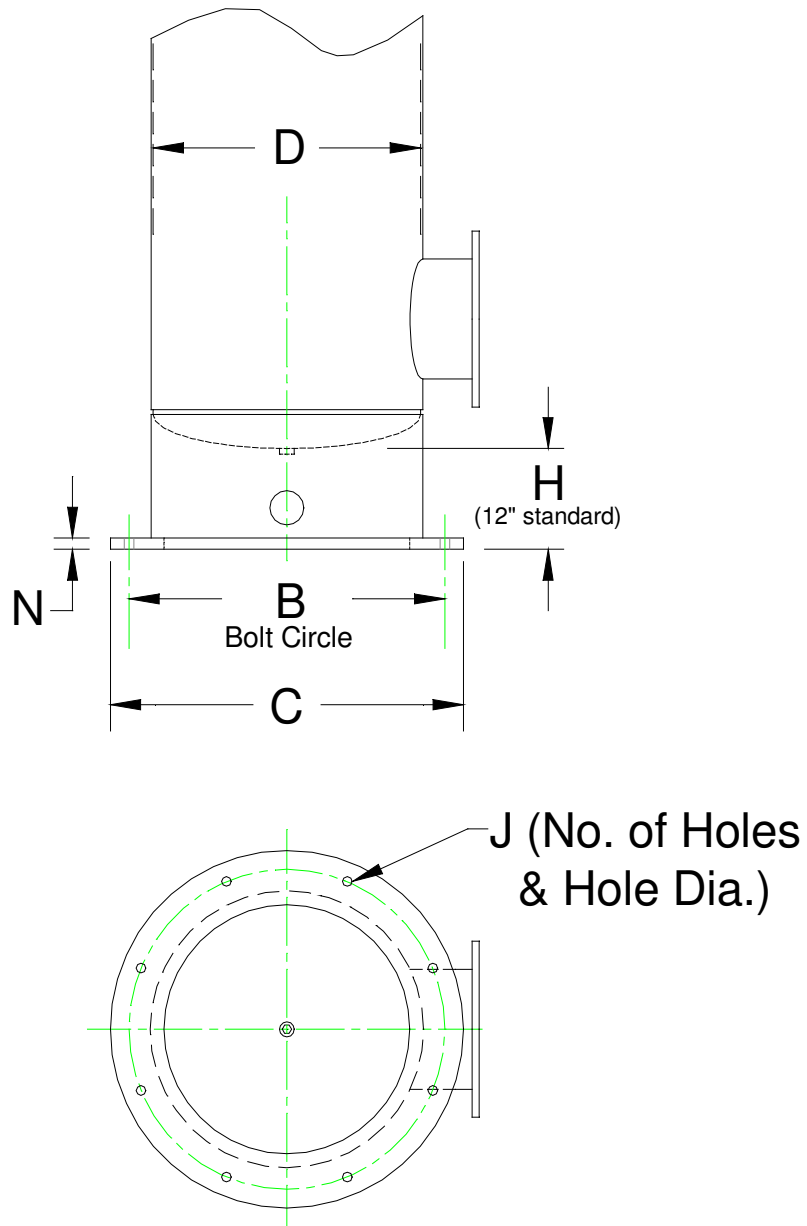

Bolt Holes Equally Spaced and
Straddle Vessel Center Lines

SKIRT & BASE RING

D Silencer Nominal Dia.	Dimensions in Inches					Est. Wt. (Lbs.)
	B Bolt Circle	C Ring OD	H	J No. & Hole Dia.	N Ring Thk.	
12	16	18	Skirt height specified on an application basis	4 - 7/8	3/8	55
14	18	20		4 - 7/8	3/8	62
16	20	22		4 - 7/8	3/8	75
18	22	24		4 - 7/8	3/8	85
20	24	26		4 - 7/8	3/8	95
22	26	28		4 - 7/8	3/8	100
24	28	30		4 - 7/8	3/8	115
26	30	32		4 - 7/8	3/8	130
28	32	34		4 - 7/8	3/8	140
30	34	36		4 - 7/8	3/8	150
36	40	42		4 - 7/8	3/8	190
42	46	48		8 - 7/8	1/2	300
48	52	54		8 - 7/8	1/2	350
54	58	60		8 - 7/8	1/2	410
60	65	68		12 - 1 1/8	3/4	570
66	71	74		12 - 1 1/8	3/4	640
72	77	80		12 - 1 1/8	3/4	950

Notes:

1. Dimensions may change depending on silencer weight and application load requirements.
2. Skirt & Base Ring Supports available for larger diameter silencers upon request.

VANEC Industrial Silencers
716-827-4959