

# Accessories

***VANEC***

**Vanec Industrial Silencers**  
3374 Benzing Road  
Orchard Park, New York 14127  
Tel. (716) 827-4959 Fax (716) 827-1041  
E-Mail: [info@vanec.com](mailto:info@vanec.com)

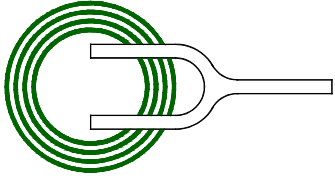

**VANEC**

## VERTICAL LUG SUPPORTS

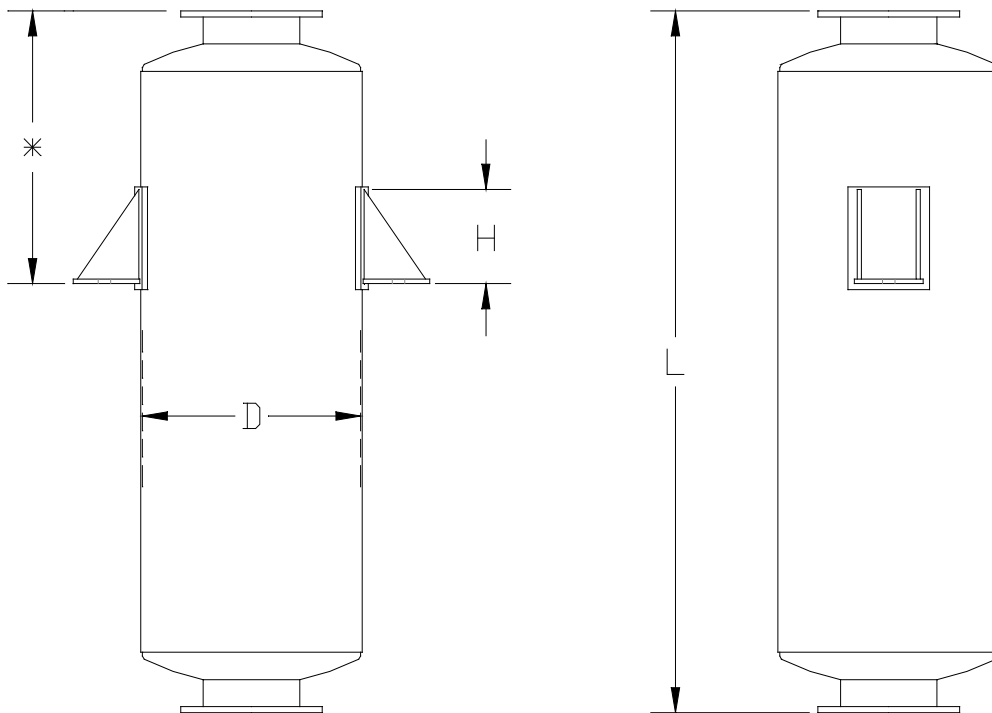
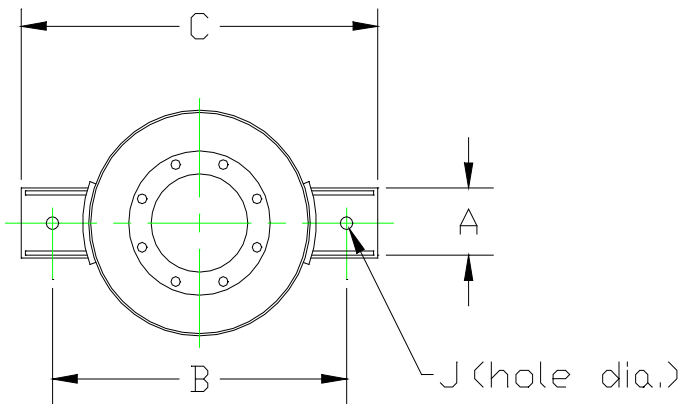

\* Lugs typically set at  $1/3 \times L$   
(unless otherwise specified)

# VERTICAL LUG SUPPORTS

D Silencer Nominal Dia.	Dimensions in Inches					Est. Wt. per Lug (Lbs.)
	A	B Bolt Circle	C	H	J Hole Dia.	
8	3	11	14	5	3/4	3
10	3	13	16	5	3/4	3
12	3	15	18	5	3/4	3
14	4	18	22	6	1	7
16	4	20	24	6	1	7
18	4	22	26	6	1	7
20	4	24	28	6	1	7
22	4	26	30	6	1	7
24	4	28	32	6	1	7
26	4	30	34	6	1	7
28	4	32	36	6	1	7
30	4	34	38	6	1	7
36	4	40	44	6	1	7
42	6	48	54	9	1½	12
48	6	54	60	9	1½	12
54	6	60	66	9	1½	12

**Notes:**

1. Dimensions may change depending on silencer weight and application load requirements.
2. Lugs available for larger diameter silencers upon request.

**VANEC** Industrial Silencers  
716-827-4959

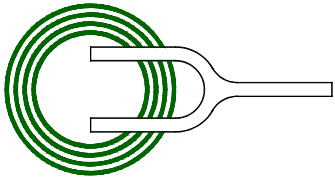

# VANEC

## VERTICAL ANGLE LEGS

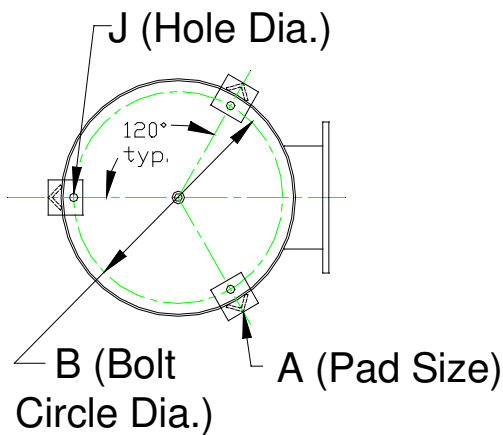
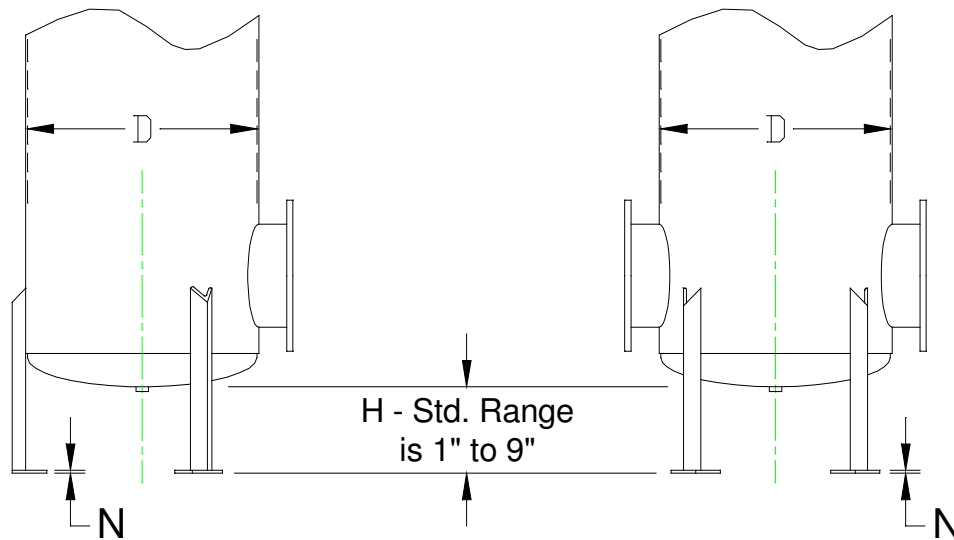

3 Leg  
Arrangement

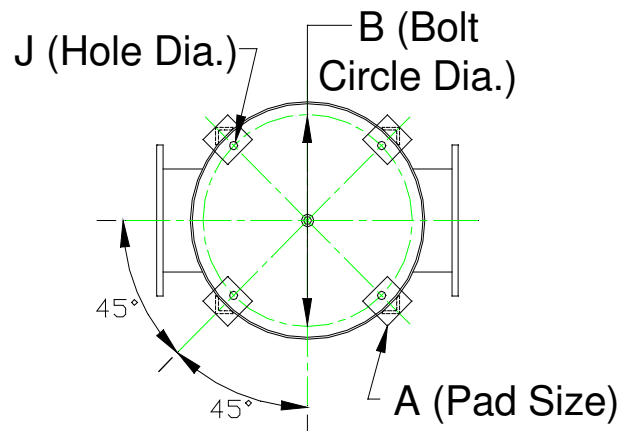

4 Leg  
Arrangement

# VERTICAL ANGLE LEGS

D Silencer Nominal Dia.	Dimensions in Inches					Est. Wt. per Leg (Lbs.)
	A Pad Size	B Bolt Circle	H	J Hole Dia.	N Pad Thk.	
12	4 x 4	10	Leg projection specified on an application basis	1	<sup>3</sup> / <sub>8</sub>	8
14	4 x 4	12		1	<sup>3</sup> / <sub>8</sub>	8
16	4 x 4	14		1	<sup>3</sup> / <sub>8</sub>	8
18	4 x 4	16		1	<sup>3</sup> / <sub>8</sub>	8
20	4 x 4	18		1	<sup>3</sup> / <sub>8</sub>	8
22	4 x 4	20		1	<sup>3</sup> / <sub>8</sub>	8
24	6 x 6	21		1 <sup>1</sup> / <sub>8</sub>	<sup>1</sup> / <sub>2</sub>	16
26	6 x 6	23		1 <sup>1</sup> / <sub>8</sub>	<sup>1</sup> / <sub>2</sub>	16
28	6 x 6	25		1 <sup>1</sup> / <sub>8</sub>	<sup>1</sup> / <sub>2</sub>	16
30	6 x 6	27		1 <sup>1</sup> / <sub>8</sub>	<sup>1</sup> / <sub>2</sub>	16
36	6 x 6	33		1 <sup>1</sup> / <sub>8</sub>	<sup>1</sup> / <sub>2</sub>	16
42	6 x 6	39		1 <sup>1</sup> / <sub>4</sub>	<sup>1</sup> / <sub>2</sub>	16
48	7 x 7	45		1 <sup>1</sup> / <sub>4</sub>	<sup>5</sup> / <sub>8</sub>	32
54	7 x 7	51		1 <sup>1</sup> / <sub>4</sub>	<sup>5</sup> / <sub>8</sub>	32
60	7 x 7	57		1 <sup>1</sup> / <sub>4</sub>	<sup>5</sup> / <sub>8</sub>	32
66	7 x 7	63		1 <sup>1</sup> / <sub>4</sub>	<sup>5</sup> / <sub>8</sub>	32
72	7 x 7	69		1 <sup>1</sup> / <sub>4</sub>	<sup>5</sup> / <sub>8</sub>	32

**Notes:**

1. Dimensions may change depending on silencer weight and application load requirements.
2. Angle legs available for larger diameter silencers upon request.

**VANEC Industrial Silencers**  
716-827-4959

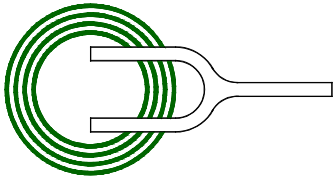

# VANEC

## VERTICAL PIPE TRUNNION SUPPORTS

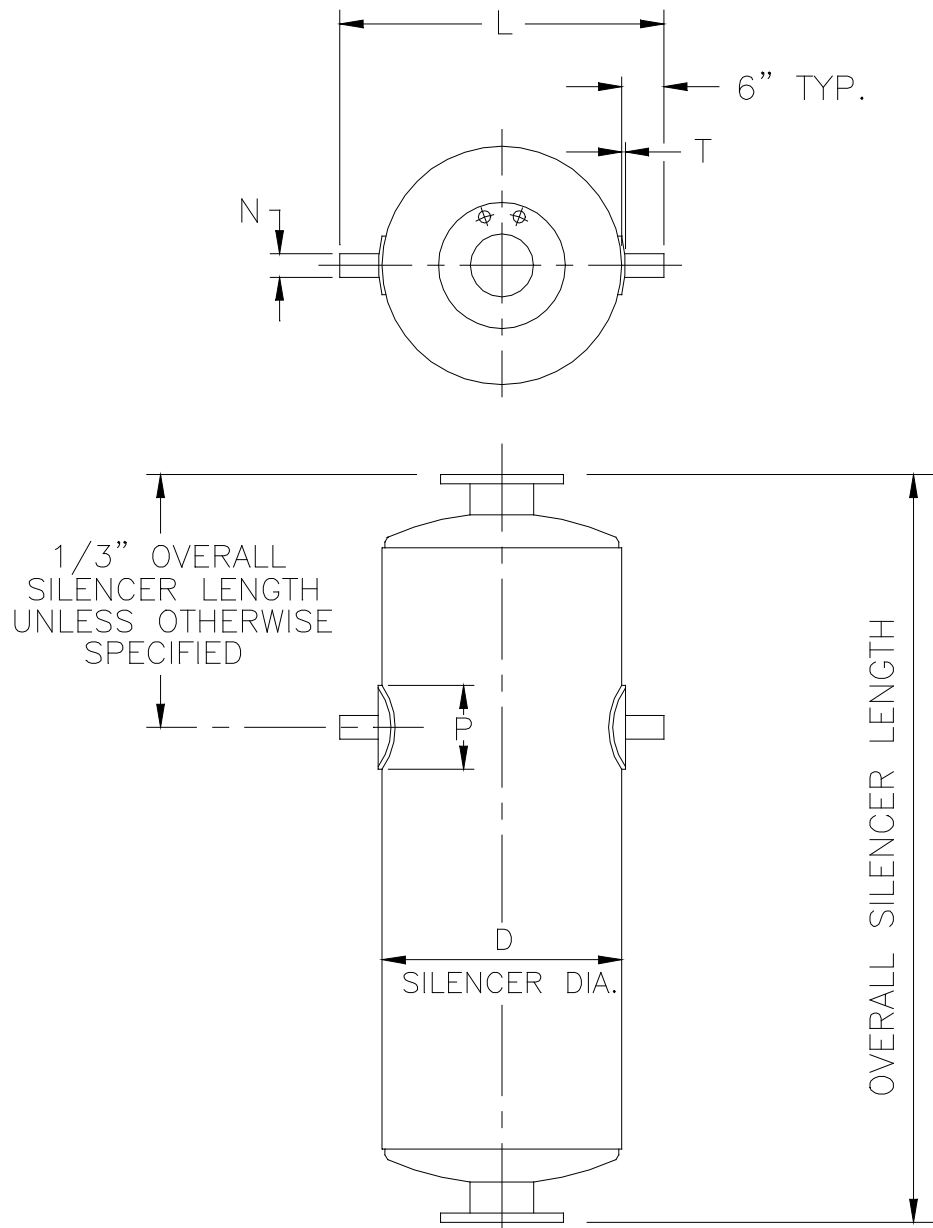

VERTICAL PIPE TRUNNION SUPPORT  
(2 REQ'D PER UNIT)

# VERTICAL PIPE TRUNNION SUPPORTS

D Silencer Nominal Dia.	Dimensions in Inches				Est. Wt. per Set of Two (Lbs.)
	N Pipe Dia.	L	P Pad Dia.	T Pad Thk.	
18	2 <sup>3</sup> / <sub>8</sub>	30	6	1/4	14
20	2 <sup>3</sup> / <sub>8</sub>	32	6	1/4	14
22	2 <sup>3</sup> / <sub>8</sub>	34	6	1/4	14
24	2 <sup>3</sup> / <sub>8</sub>	36	6	1/4	14
26	2 <sup>3</sup> / <sub>8</sub>	38	6	1/4	14
28	2 <sup>3</sup> / <sub>8</sub>	40	6	1/4	14
30	2 <sup>3</sup> / <sub>8</sub>	42	6	1/4	14
32	2 <sup>3</sup> / <sub>8</sub>	44	6	1/4	14
36	3 1/2	48	12	3/8	48
42	3 1/2	54	12	3/8	48
48	3 1/2	60	12	3/8	48
54	3 1/2	66	12	3/8	48
60	4 1/2	72	18	1/2	102
66	4 1/2	78	18	1/2	102
72	4 1/2	84	18	1/2	102

**Notes:**

1. Dimensions may change depending upon silencer weight and application requirements.
2. Trunnions available for larger diameter silencers upon request.

**VANEC** Industrial Silencers  
716-827-4959

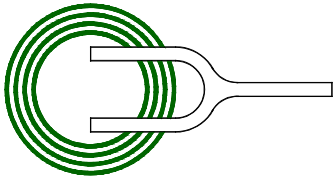

# VANEC

## HORIZONTAL SADDLE SUPPORTS

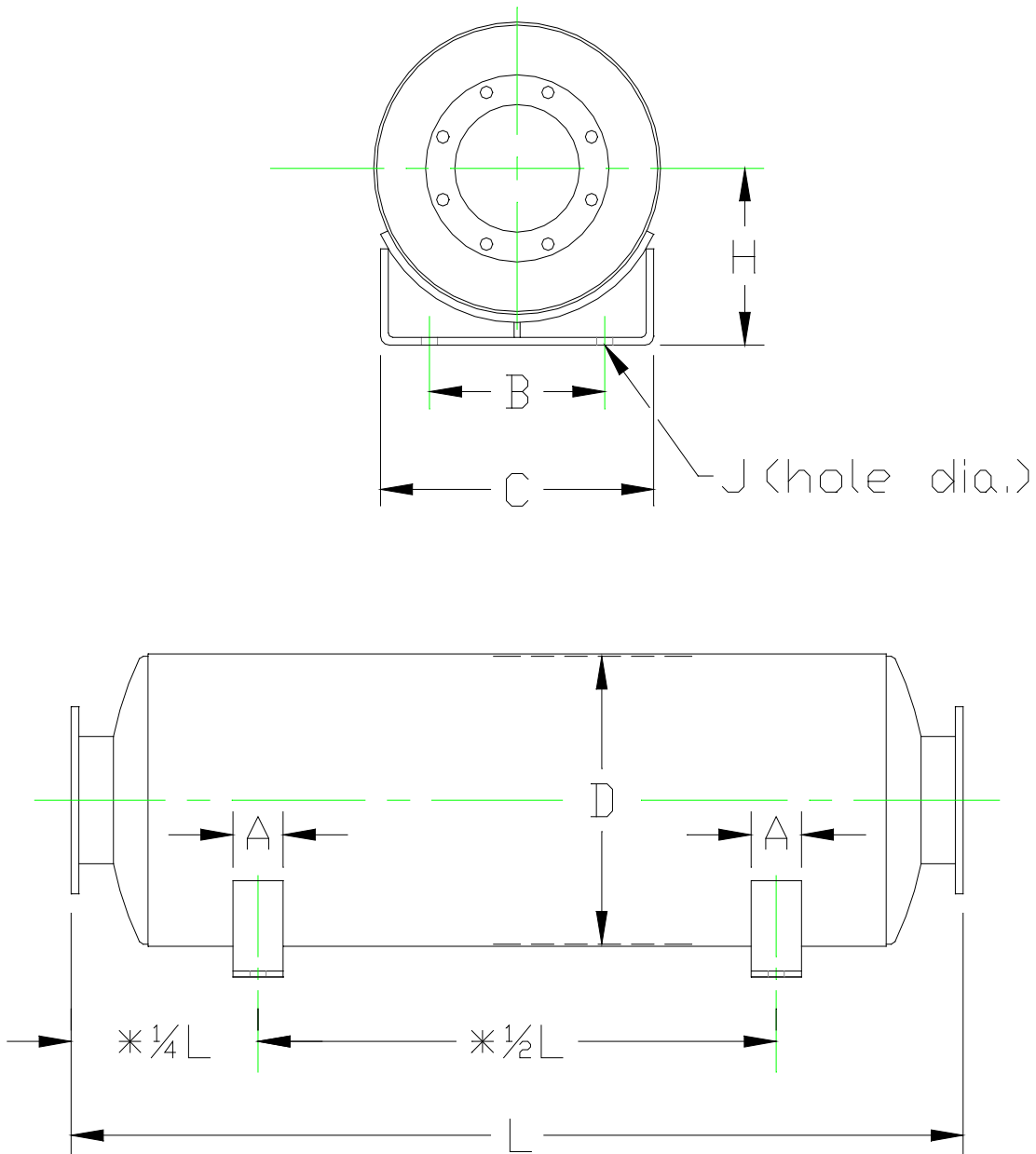

\* Saddles typically set as shown  
(unless otherwise specified)

# HORIZONTAL SADDLE SUPPORTS

D Silencer Nominal Dia.	Dimensions in Inches					Est. Wt. per Saddle (Lbs.)
	A	B	C	H	J Hole Dia.	
8	3	5	8	6	1/2	5
10	3	6 1/2	10	7	1/2	6
12	3	8	12	8	1/2	8
14	3	9	13	9	1/2	8
16	4	10	14	10	3/4	12
18	4	11	16	11	3/4	13
20	4	12	18	12	3/4	14
22	4	13	20	13	3/4	15
24	4	14	22	14	3/4	16
26	5	15	23	15	3/4	22
28	5	17	25	16	3/4	24
30	5	18	27	17	3/4	25
36	5	22	32	20	3/4	30
42	6	25	38	23	3/4	40
48	6	28	42	26	3/4	46
54	6	32	48	29	3/4	52

**Notes:**

1. Dimensions may change depending on silencer weight and application load requirements.
2. Saddles available for larger diameter silencers upon request.

**VANEC** Industrial Silencers  
716-827-4959

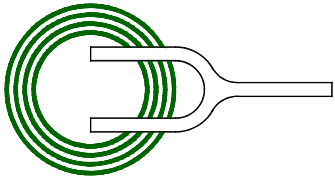

# VANEC

## HORIZONTAL LUG SUPPORTS

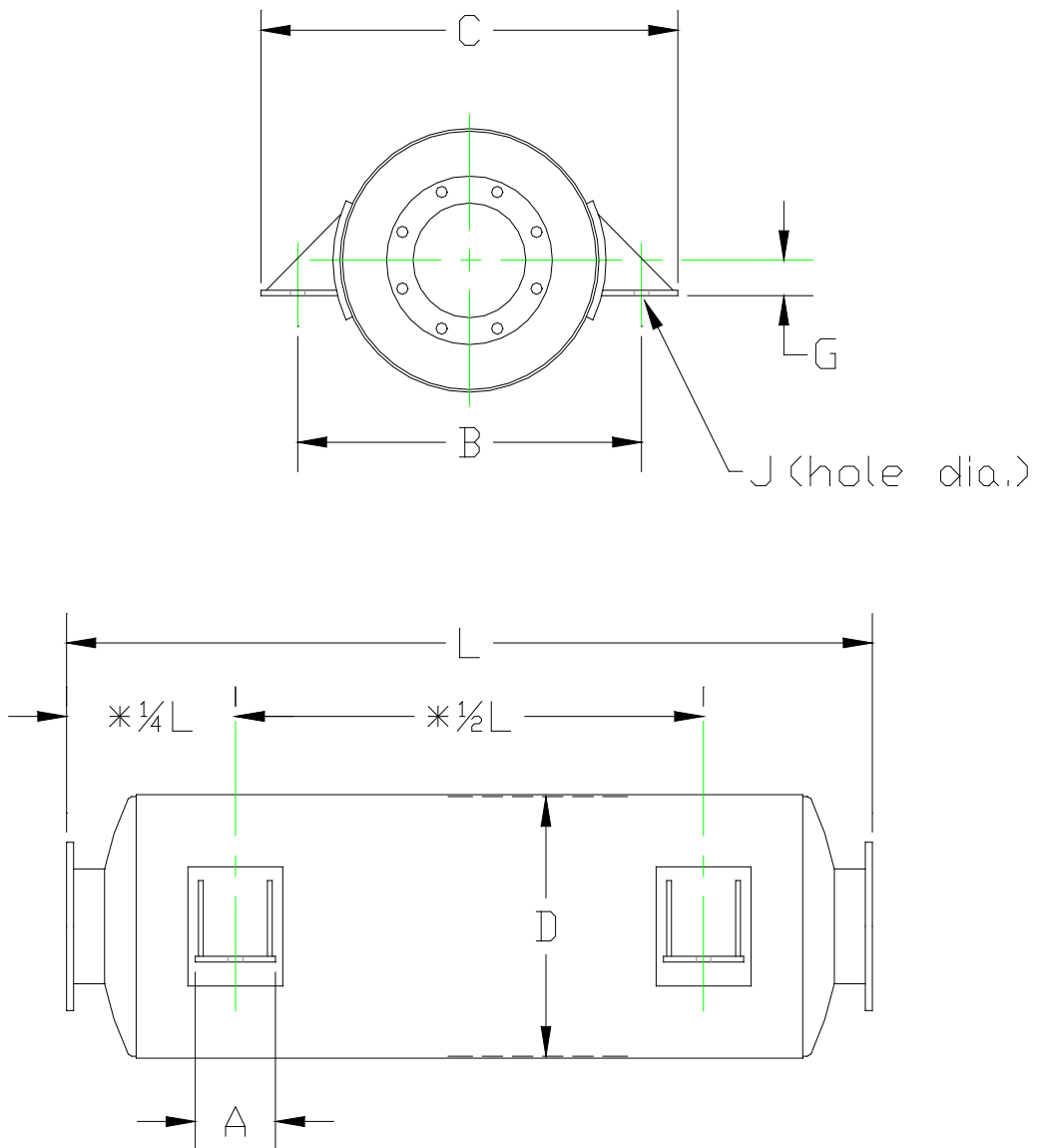

\* Lugs typically set as shown  
(unless otherwise specified)

# HORIZONTAL LUG SUPPORTS

D Silencer Nominal Dia.	Dimensions in Inches					Est. Wt. per Lug (Lbs.)
	A	B Bolt Circle	C	G Offset	J Hole Dia.	
8	3	11	14	1½	¾	3
10	3	13	16	1½	¾	3
12	3	15	18	1½	¾	3
14	4	18	22	1½	1	7
16	4	20	24	1½	1	7
18	4	22	26	1½	1	7
20	4	24	28	1½	1	7
22	4	26	30	1½	1	7
24	4	28	32	1½	1	7
26	4	30	34	1½	1	7
28	4	32	36	1½	1	7
30	4	34	38	3	1	7
36	4	40	44	3	1	7
42	6	48	54	3	1½	12
48	6	54	60	3	1½	12
54	6	60	66	3	1½	12

**Notes:**

1. Dimensions may change depending on silencer weight and application load requirements.
2. Lugs available for larger diameter silencers upon request.

**VANEC** Industrial Silencers  
716-827-4959

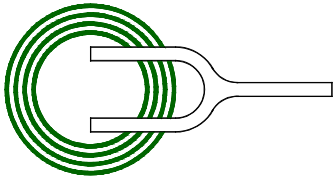

# VANEC

## SKIRT & BASE RING

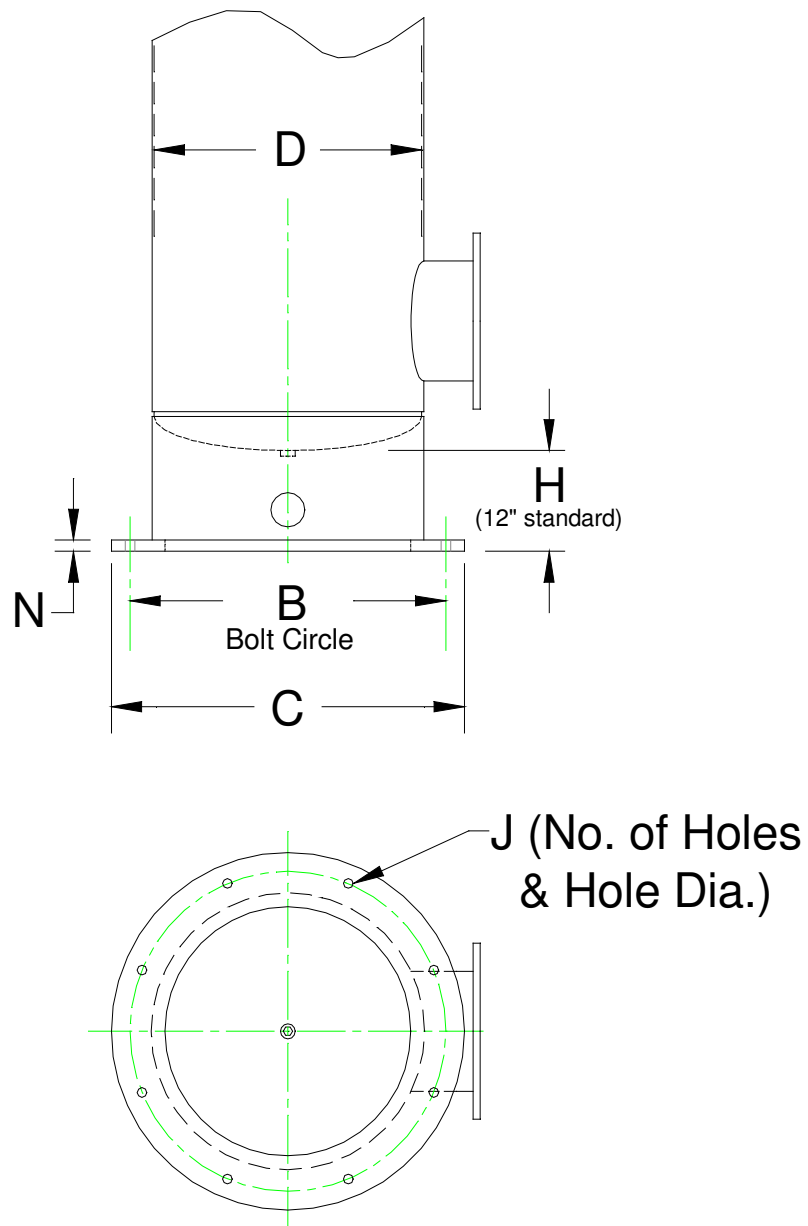

Bolt Holes Equally Spaced and  
Straddle Vessel Center Lines

# SKIRT & BASE RING

D Silencer Nominal Dia.	Dimensions in Inches					Est. Wt. (Lbs.)
	B Bolt Circle	C Ring OD	H	J No. & Hole Dia.	N Ring Thk.	
12	16	18	Skirt height specified on an application basis	4 - 7/8	3/8	55
14	18	20		4 - 7/8	3/8	62
16	20	22		4 - 7/8	3/8	75
18	22	24		4 - 7/8	3/8	85
20	24	26		4 - 7/8	3/8	95
22	26	28		4 - 7/8	3/8	100
24	28	30		4 - 7/8	3/8	115
26	30	32		4 - 7/8	3/8	130
28	32	34		4 - 7/8	3/8	140
30	34	36		4 - 7/8	3/8	150
36	40	42		4 - 7/8	3/8	190
42	46	48		8 - 7/8	1/2	300
48	52	54		8 - 7/8	1/2	350
54	58	60		8 - 7/8	1/2	410
60	65	68		12 - 1 1/8	3/4	570
66	71	74		12 - 1 1/8	3/4	640
72	77	80		12 - 1 1/8	3/4	950

**Notes:**

1. Dimensions may change depending on silencer weight and application load requirements.
2. Skirt & Base Ring Supports available for larger diameter silencers upon request.

**VANEC Industrial Silencers**  
716-827-4959

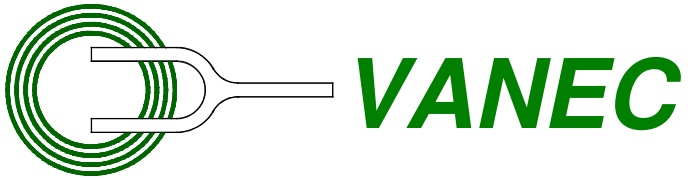

## WEATHERHOODS

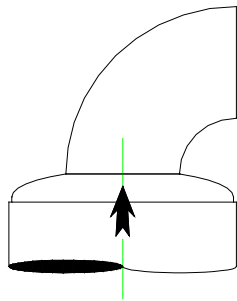

90° OUTLET ELBOW

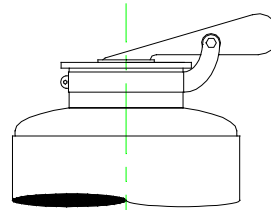

COUNTERWEIGHTED  
RAINCAP

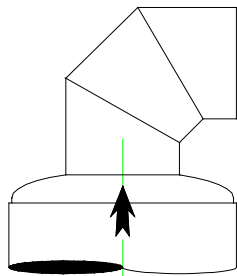

90° MITERED ELBOW

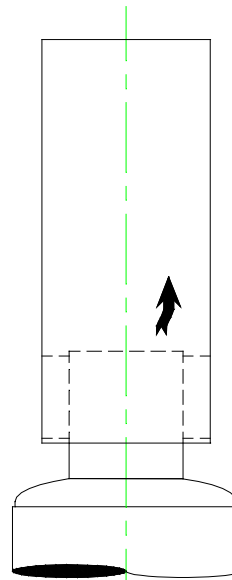

STACK EXTENSION

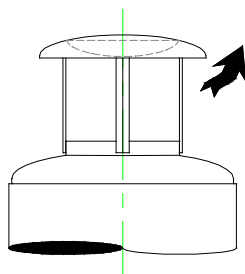

DISHED HEAD  
TYPE CAP

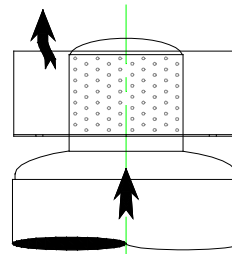

UPFLOW DIFFUSER

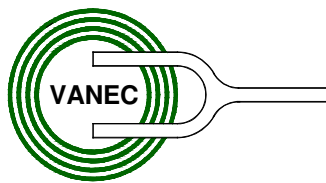

**VIBRATION AND NOISE ENGINEERING CORPORATION**

***VANEC* Industrial Silencers**

3374 Benzing Road

Orchard Park, New York 14127

Tel. (716) 827-4959 Fax (716) 827-1041

E-Mail: [info@vanec.com](mailto:info@vanec.com)